

1 Clean the area on the product where the label is to be applied.

Use alcohol or glass cleaner to remove dirt, dust and grease.

Pro tip: Use a microfiber or lint free cloth to wipe the surface. Dust or dirt particles left behind on the surface may show through or leave air bubbles under the label after its applied.

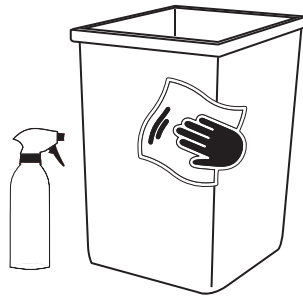

What you will need:

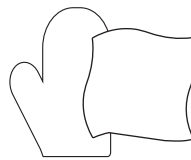

Microfiber Glove or Lint Free Cloth

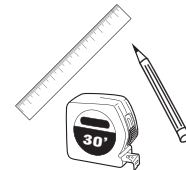

Ruler or Tape Measure, Soft Pencil



Label
Glass Cleaner or Alcohol

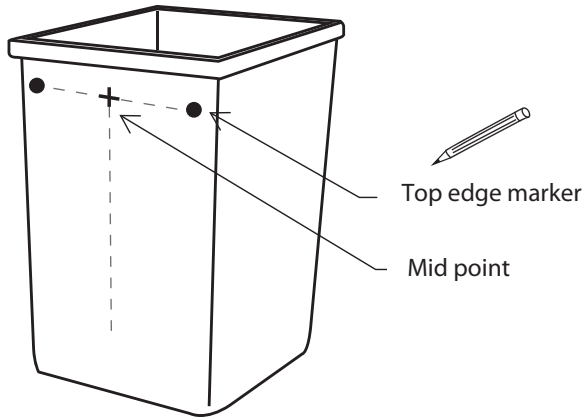

Top edge marker

Mid point

2 Label location

A. Before removing the backing paper to expose the adhesive, decide where on the product you would like to apply the label.

B. Mark the mid point on the area where the label is to be applied to the container.

C. Mark spots on the container to line up the top horizontal edge of the label.

Pro tip: To locate the top horizontal location for the label, measure down from the container's top edge, lip or other location. Make 2 marks to which the top edge of the label can be aligned.

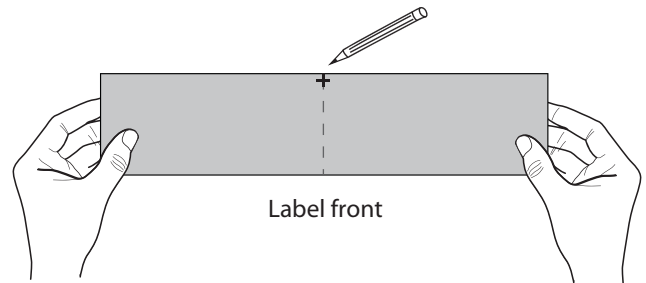

Label front



Label back

3 Applying the labels

A. Lay the label face up on a flat surface and make a small mark on the top to indicate the middle of the label.

B. Lay the label face down on a clean dry surface, locate the split in the backing sheet. Fold a 2" section of the white backer paper back to expose the adhesive on one side.

4 A. Flip the label over so the adhesive side of the label faces the application area on the container.

B. Align top edge and mid point of label with marked horizontal top edge and mid point marked on container.

C. Run edge of finger down the middle of the label and start to adhere the label.

D. With one hand, slowly remove the backing sheet from one side of the label while simultaneously applying even pressure to the label with the other hand to adhere it to the container's surface.

E. Repeat the application process on the other side. Bend back the other side of the label to pull the backing sheet while simultaneously smoothing the label onto the container's surface. Completely remove backer while smoothing label onto can.

F. Once backer is removed and label fully adhered, smooth out any bubbles or wrinkles.

Pro tip: To minimize the chance of wrinkles, do not remove all of the backing sheet prior to applying the label. Using a microfiber glove or cloth may help in smoothing out the label as the backing sheet is removed and the label adheres to the container. Working slowly will help ensure the label adheres with no wrinkles and air bubbles. Should bubbles remain, a pin prick in the bubble may allow the surface to be smoothed out.

